



FAIRGROUNDS  
SOUTHERN  
**Ideal  
home  
show**®

# EXHIBITOR MANUAL

## North Carolina State Fairgrounds



## September 22-24th, 2017

This Exhibitor Manual has been compiled to help you and your staff with complete details about all phases of the exhibition process at the Southern Ideal Home Show.

Enclosed you will find helpful information to make your participation in our show successful.

**We strongly urge that you give this manual to those having responsibility for your participation in the show.**

[FairgroundsRaleighHomeShow.com](http://FairgroundsRaleighHomeShow.com)

**MARKETPLACE | EVENTS**  
Largest Home Show Producer in North America

# SHOW MANAGEMENT

The Southern Ideal Home Show is produced and managed by:

Marketplace Events

590 New Waverly Place Ste 210

Cary, NC 27518

Chiara Renella-Brooks, Show Manager

P: (919) 306-9463

[ChiaraRB@mpeshows.com](mailto:ChiaraRB@mpeshows.com)

[www.marketplaceevents.com](http://www.marketplaceevents.com)

---

# SHOW FACILITY

The Southern Ideal Home Show is held at the North Carolina State Fairgrounds in the Exposition Building and the Jim Graham Building.

North Carolina State Fairgrounds

1025 Blue Ridge Road

Raleigh, NC 27607

[ncstatefair.org](http://ncstatefair.org)

---

# UTILITIES

Electricity, Telephone, Water, etc.

These services are provided by the North Carolina State Fairgrounds.

Standard electrical service is included with your booth space and does not need to be ordered. If you have special electrical requirements, please contact Erin Calabritto at [erinc@mpeshows.com](mailto:erinc@mpeshows.com) at least two weeks prior to move-in.

Please refer to the applicable order forms which can be found under the [Exhibitor Kit](#) section of our website, located at the bottom of the Home Page.

# MOVE-IN | MOVE-OUT DAYS AND HOURS

All accounts must be paid in full before you can move in. For safety reasons, no one under the age of 16 is permitted in the halls or dock areas during move-in/out.

**You may use your own carts, hand trucks, dollies, etc.**



**Dismantling your booth prior to show close at 6:00pm on Sunday is strictly prohibited. Your cooperation is appreciated.**

## General Move-In Dates/Time

Monday	September 18 <sup>th</sup> , 2017	12:00pm - 5:00pm
Tuesday	September 19 <sup>th</sup> , 2017	8:00am - 5:00pm
Wednesday	September 20 <sup>th</sup> , 2017	8:00am - 5:00pm
Thursday	September 21 <sup>st</sup> , 2017	8:00am - 5:00pm

You must be completely set up by the end of the day on Thursday; there is no move-in permitted on Friday morning.

## General Move-Out Dates/Time

Sunday	September 24 <sup>th</sup> , 2017	6:01pm - 10:00pm
Monday	September 25 <sup>th</sup> , 2017	8:00am - 3:00pm

All exhibit halls must be cleared by 3:00pm.

---

## SHOW HOURS

Friday	September 22 <sup>nd</sup> , 2017	10:00am - 8:00pm
Saturday	September 23 <sup>rd</sup> , 2017	10:00am - 8:00pm
Sunday	September 24 <sup>th</sup> , 2017	11:00am - 6:00pm

Exhibitors may enter the show one hour before opening.

## EXHIBITOR BADGES

Exhibitor badges are NOT mailed out prior to the show. Badges can be picked up in the Show Office (Jim Graham Building) during move-in and during show hours. Plastic badge holders are provided.

Exhibitor badges are required to identify you as an authorized exhibitor. Exhibitors will not be allowed access to the show floor during move-in or show days without a badge.

Six (6) exhibitor badges are provided for each 100 square feet of space purchased, with a maximum allotment of 24 badges per company.

If you have different staff members working your booth on different days, you are encouraged to drop off your badge each night in the Show Office, so that your company does not run out of badges during the show.

Exhibitor badges must not be used as admission tickets for guests and cannot be left at will call.

---

## SHOW OFFICE

During move-in, show hours and move-out, Show Management will maintain a show office in Jim Graham Building of the North Carolina State Fairgrounds. The office is to the right, at the end of the hallway as you enter from the breezeway that connects the Exposition Building to the Jim Graham Building. Look for the show office sign.

---

## EXHIBITOR ENTRANCES DURING SHOW HOURS

During show hours, exhibitors may use the main entrances to the Exposition Building and the Jim Graham Building. An exhibitor badge will be required to enter the show floor.

You will not be allowed to bring in exhibit supplies through the main entrance during show hours. Please visit the show office to make arrangements as needed for bringing in supplies during the show.

---

## COMPLIMENTARY TICKETS

Each exhibitor will receive 10 complimentary tickets for each 100 square feet of space purchased with a maximum allotment of 40 tickets. These will be mailed out three weeks prior to the show. Tickets will only be mailed out if your account has been settled in full.

**COMPLIMENTARY TICKETS ARE NOT PERMITTED TO BE DISTRIBUTED AT THE ENTRANCE TO THE SHOW.** Use your tickets to invite potential customers to the show, as a thank you to good customers or for friends and family.

---

## WILL CALL

Will Call will be at the Box Office at the main entrance to the show in the Exposition Building. Tickets for your guests can be left at Will Call, providing that they are in an envelope with their first and last name on it, and how many tickets you have put inside. These will be filed by last name at Will Call, so please inform your invited guests to ensure they are able to get into the show with ease! Please use your tickets for guests—exhibitor badges should not be left at Will Call for attendees.

## DECORATOR SERVICES

Southern Exposition Services (SES) is the show decorator and provides carpet, tables, chairs, cleaning, signage, etc. Please order these items directly from them. The forms are available on the [Exhibitor Kit](#) section of our website.

---

## PARKING

Exhibitor parking at the fairgrounds is free and unlimited.

---

## UTILITIES AND SERVICES POLICY

The North Carolina State Fairgrounds is happy to provide utilities and services at prevailing rates. Current rate sheets for labor, equipment rental and services are available on request. For safety reasons, NCSF personnel must perform installation of all utility services.

Utilities Forms can be found under the [Exhibitor Kit](#) section of our website, which is located at the bottom of the Home Page.

---

## FOOD AND BEVERAGE SAMPLING

Bulk food or beverage sales can be considered for Fair Administration approval provided that any exhibitor offering food products must be pre-approved and adhere to the following guidelines.

Food products which are approved to be sold at an event must be packaged in bulk form and sealed for off-premises consumption. To avoid any confusion and consistently enforce terms of contractual agreements, a list of exhibitors selling food or beverage in bulk form along with a description of the proposed sample should be submitted to the Fairgrounds at least one month prior to the event for review.

The following are sampling guidelines applicable for approved exhibitor samples within State Fairgrounds facilities which have a food and beverage concessions contract:

- Sample being offered must be a product being offered by the exhibitor.
- Sample size - Beverage - sample amount 2 oz. or less
- Sample size - Food – sample should be 1 square inch or less and fit in a standard 1 inch condiment cup.
- Approved sampling must be offered in compliance with any regulatory requirements from Wake Environmental Services (919) 856-7419.
- Any approved sample containing alcohol will be subject to the current State Fair Alcohol Policy.

Please contact Erin Calabritto at [erinc@mpeshows.com](mailto:erinc@mpeshows.com) at least one month prior to the show to apply for sampling consideration.

# VEHICLES IN EXHIBITS

If you plan on having a vehicle in your booth as part of your display, please contact Show Management for approval and move-in instructions.

- Visqueen must be put down on the floor before the vehicle is driven into place.
- All vehicles must have a locking gas cap or gas cap sealed with tape and no more than 1/4 tank of gas in the vehicle.
- A set of keys must be left with Show Management for the duration of the show.
- All vehicle batteries must be disconnected and cables taped.

---

## BOOTH INFORMATION, RULES & REGULATIONS

Exhibit booths will have an 8' draped back wall. On each side, a draped side rail will extend from the back of the booth to the front of the booth at a height of 32". The drape color is black. **Tables, chairs, electricity etc. are not included with the cost of your exhibit booth.**

### Flooring

Flooring is not included in the cost of your exhibit booth. **It is mandatory that all booths are carpeted** or have some type of clean, professional-looking floor covering that covers 100% of the booth's square footage.

### Table Skirting

**It is mandatory that all tables are properly skirted.** Skirting must go from the edge of the table to the floor on all four sides. All skirting must be pressed and neat. Use of plastic table cloths, sheets, shower curtains or any type of "makeshift" table cloths is **not permitted**. We strictly enforce this and will skirt all incorrectly skirted tables at the exhibitor's expense.

All inventory and personal items must be stored COMPLETELY OUT OF SIGHT. Your booth should look professional and inviting to the attendee.

### Staffing Your Booth

All exhibitors are expected to be in their booths during all published show hours, as we do receive consumer complaints about un-manned displays. **Our visitors pay an entrance fee and expect to be able to do business with our exhibitors at any time during show hours. If you are in violation of this rule, your company may not be permitted to exhibit with us in the future.**

Working in the aisles or distributing brochures, etc. from any other area other than your booth is prohibited. All activity must take place inside your contracted space.

**\*\*\*TENTS AND CANOPIES ARE NOT ALLOWED\*\*\***

## **Booth Guidelines**

Exhibitors are allowed to build their booth to the maximum height of 8 feet. This includes back wall and sidewalls. If your display includes a sign attached to the back wall, you must get approval from show management and the following rules apply:

- TOTAL HEIGHT OF SIGN MUST NOT EXCEED 2 FEET FROM TOP OF DRAPE LINE
- Sign must be single sided
- Professionally finished
- No PVC pipe allowed

If you are using side walls as part of your display they must be completely finished on BOTH sides. No exposed wires, frames, wood must be exposed for the public or your neighbor to see.

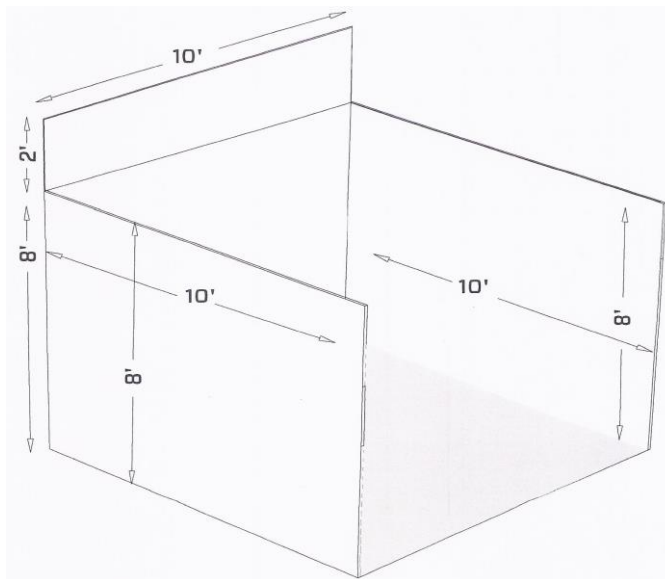

## **SECURITY**

Security is provided and guards will be on duty throughout the event. Every reasonable precaution will be taken to protect exhibitors' property, but Show Management assumes no responsibility for any losses due to fire, theft, robbery, damage, accident or other causes.

---

## **INSURANCE**

Show Management is insured against public liability and property damage claims arising out of the conduct of the show. This insurance does not cover exhibitors' property, which is placed on display at the exhibitor's risk. Please refer to items #4 and 5 on your exhibitor contract/application or contact Show Management if you have questions.

---

## SHIPPING INFORMATION

Southern Exhibition Services (SES) charges a drayage fee for handling any materials delivered to the North Carolina State Fairgrounds home show expo buildings. Deliveries without company name and booth number will be declined. Contact Southern Exhibition Services if you are sending shipments ahead of your arrival. Marketplace Events and the North Carolina State Fairgrounds are not authorized to accept your shipment.

Detailed shipment information can be found in the Decorator Service Kit, under the [Exhibitor Kit](#) section of our website, which is located at the bottom of the Home Page.

For questions on move-in, move-out, or booth guidelines before or after the show, please contact your Exhibit Sales Consultant or reach out to **Erin Calabritto, Operations Coordinator** for the show.

Email: [ErinC@mpeshows.com](mailto:ErinC@mpeshows.com)

Cell: (386) 334-1713

**We thank you for exhibiting in the show and are here to help you have a great experience. Please let us know how we can be of service to you. Thank you for your business!**





FAIRGROUNDS  
SOUTHERN  
**Ideal  
home  
show**®

## EXHIBITOR RULES AND REGULATIONS CHECK LIST

- All booths must have floor covering in entire booth area.
- No signs above 8'. All signs must be professional. "Homemade" or handwritten signs are not allowed.
- If the height of your display exceeds 8' you need to notify management for approval. **Electric, tables, chairs, carpeting, water, telephone, etc. are not included with the price of your exhibit space.** These items can be ordered through Southern Exhibition Services (SES) and the North Carolina State Fairgrounds.
- Tables are to be professionally skirted with floor-length skirting. Absolutely no paper or plastic table skirts! Fine furniture is acceptable without skirting.
- Exterior of display or structure facing adjacent exhibitor or aisle must be finished or suitably decorated.
- Improve exhibit with live flowers and plants.
- Stickers, pressure adhesive and helium balloons are not permitted in the booth.
- No food or beverages may be distributed by exhibitors unless approval has been obtained from the North Carolina State Fairgrounds.
- All exhibitors are expected to be in their booths during all published show hours. If Show Management sees that you are in violation of this rule, your company may not be permitted to exhibit in future shows.
- All exhibiting companies must have an executed space agreement with Marketplace Events. Exhibitors are not permitted to assign, sublet or share booth space.
- Admission with an exhibitor badge is required.
- Exhibitors are allowed on the show floor one hour before the show opens to the public and are encouraged to arrive early and be prepared for the crowds.
- What you bring in, take out. Leave the floor in broom-clean condition.